

SBC-WP240M8-31x-S410

鍍層厚度:

Blank	: 1u"
2	: 15u"
3	: 30u"

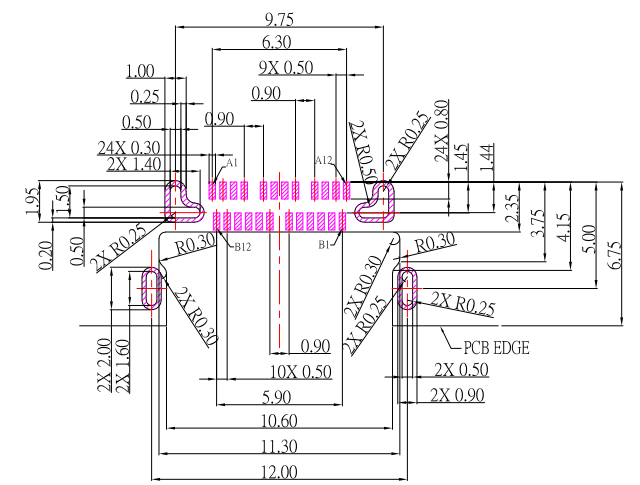
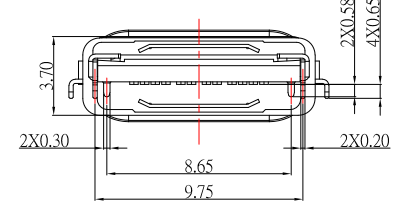
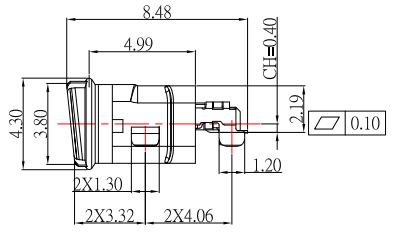
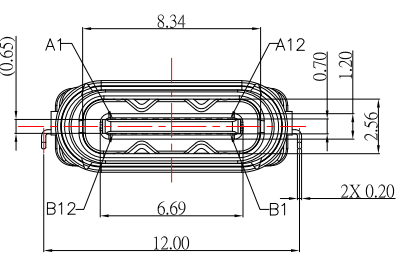
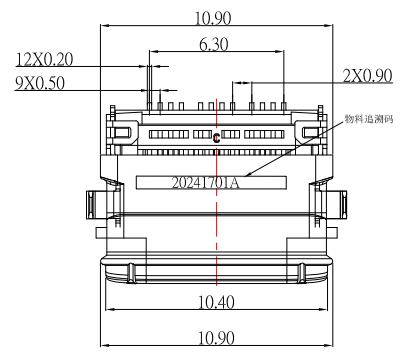

P.C.B LAYOUT

SPECIFICATIONS

- Electrical:**
- Rating: 5.0A , 20V
 - Contact Resistance: 40 mΩ Max
 - Insulation Resistance: 100 MΩ Min
 - Dielectric Withstanding Voltage: 100V AC
- Mechanical:**
- Connector Mate and Unmate Force
 - Mate force: 5~20 N
 - Unmate force: 8~20 N
- Material:**
- Housing: PA46
 - Contact: C18400
 - Shell: SUS
- Finish:**
- Contact: Plated Gold in Mating Area ;
Gold Plated on Solder Balls ;
Nickel under plated overall
 - Shell: Nickel under Plated surface layer

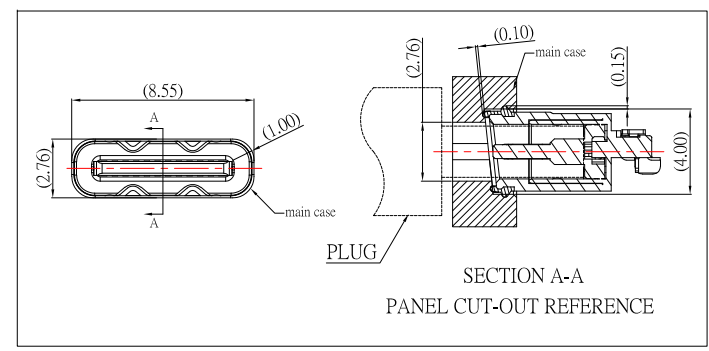
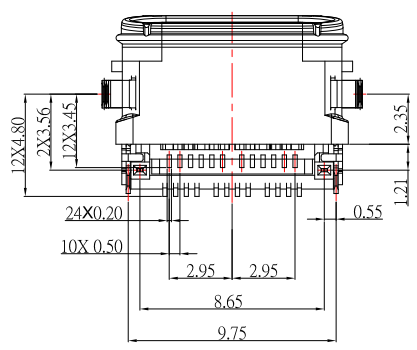

Pin:

A1	A2	A3	A4	A5	A6	A7	A8	A9	A10	A11	A12
GND	TX1+	TX1-	Vbus	CC1	D+	D-	SBU1	Vbus	RX2-	RX2+	GND
GND	RX1+	RX1-	Vbus	SBU2	D-	D+	CC2	Vbus	TX2-	TX2+	GND
B12	B11	B10	B9	B8	B7	B6	B5	B4	B3	B2	B1

CONTACT 建倚科技股份有限公司
CONTACT TECHNOLOGY CORP.

DRAWN BY:	DATE	MAT'L	TITLE	CONNECTOR
Jack Lu	10/18/24	FINISH	MODLE	USB 3.1 TYPE C 沉板式雙貼防水型 CL0.4
CHECKED BY:	DATE	SCALE	DWG NO.	SBC-WP240M8-31x-S410
Jacky Chen	10/18/24	1 : 1	PART NO.	SBC-WP240M8-31x-S410
APPROVED BY:	DATE	SHEET NO.	1 of 2	
Tony Kao	10/18/24			

ITEM NO.	DESCRIPTION	DRAWN	DATE

TOLERANCE UNLESS OTHERWISE STATED :	Up to 5 ±0.2 Above 5 ~ 15 ±0.3 Above 15 ~ 30 ±0.4 Above 30 ~ 50 ±0.5 Angle ±0.3	3RD. ANGEL'S	UNITS	MM
-------------------------------------	---	--------------	-------	----